

# RuggedSwitch™ RS969



## Installation Guide

[www.ruggedcom.com](http://www.ruggedcom.com)

## Federal Communications Commission Radio Frequency Interference Statement

*This equipment has been tested and found to comply with the limits for a Class A digital device pursuant to Part 15 of the FCC Rules. These limits are designed to provide reasonable protection against harmful interference when the equipment is operated in a commercial environment. This equipment generates, uses and can radiate radio frequency energy and, if not installed and used in accordance with the instruction manual, may cause harmful interference to radio communications. Operation of this equipment in a residential area is likely to cause harmful interference in which case the user will be required to correct the interference on his own expense.*

### *Warning:*

*Changes or modifications not expressly approved by RuggedCom Inc. could void the user's authority to operate the equipment.*

### **Caution:**

This product contains a laser system and is classified as a “**CLASS 1 LASER PRODUCT**”.

Caution – Use of controls or adjustments or performance of procedures other than those specified herein may result in hazardous radiation exposure. This product contains no user serviceable parts. Attempted service by unauthorized personnel shall render all warranties null and void.

Should this device require service see the “Warranty and Service” section of this installation guide.

### **Important:**

The RS969 family of products should be installed in a **restricted access location** where access can only be gained by service personnel or users who have been instructed about the reasons for the restrictions applied to the location and about any precautions that shall be taken; and access is through the use of a tool or lock and key, or other means of security, and is controlled by the authority responsible for the location.

### **Trademarks:**

*Ethernet* is a trademark of Xerox Corporation

*RuggedSwitch, RuggedRated, ROS and eRSTP* are trademarks of RuggedCom® Inc.

## Table of Contents

1	Product Overview .....	4
1.1	RS969 Family Ports/Connectors Description .....	5
2	Installation .....	7
2.1	DIN Rail Mounting .....	7
2.2	Ingress Protection IP67 .....	8
2.3	Power Supply Wiring and Grounding .....	9
2.3.1	Power Supply Input Connectors Description .....	9
2.3.2	Single AC Power Supply Wiring Examples .....	12
2.3.3	Single DC Power Supply Wiring Examples .....	13
2.3.4	Dual Power Supplies – DC and AC Inputs .....	14
2.4	Dielectric Strength (HIPOT) Testing .....	16
2.5	Failsafe Alarm Relay Wiring and Specifications .....	17
2.6	Console Port Wiring .....	18
2.7	Fast Ethernet Ports – Signal Description .....	19
3	Technical Specifications .....	20
3.1	Operating Environment .....	20
3.2	Power Supply Specifications .....	20
3.3	Failsafe Relay Specifications .....	20
3.4	Twisted Pair Data Port Specifications .....	21
3.5	Fiber Optical Port Specifications .....	21
3.6	IEC 61850-3 Type Tests .....	22
3.7	IEEE 1613 Type Tests .....	23
3.8	IEC Environmental Type Tests .....	23
3.9	Mechanical Specifications .....	24
3.10	Agency Approvals .....	26
4	Accessories .....	27
4.1	POWER (1/unit) .....	27
4.2	CONSOLE (1/unit) .....	27
4.3	FAILSAFE (1/unit) .....	28
4.4	ETHERNET (8/unit) .....	29
4.5	LC FIBER OPTIC (2/unit) .....	30
5	Warranty .....	31

# 1 Product Overview

The RuggedSwitch™ RS969 is an industrially hardened, fully managed Ethernet switch providing dual fiber optical Gigabit Ethernet ports and eight Fast Ethernet copper ports in an IP65/IP67 rated package for protection against low pressure jets of water (IP65) or temporary immersion in water (IP67). Designed to operate reliably in harsh industrial environments the RS969 provides a high level of immunity to electromagnetic interference and heavy electrical surges typical of environments found in electric utility substations, factory floors or in curb side traffic control cabinets. An operating temperature range of -40°C to +85°C coupled with hazardous location certification and IP65/IP67 rated waterproof packaging allows the RS969 to be placed in virtually any location. The embedded Rugged Operating System (ROS™) provides advanced networking features such as Enhanced Rapid Spanning Tree (eRSTP™), Port Rate Limiting and a full array of intelligent functionality for high network availability and manageability.

## Ethernet Ports

- 2 - Fiber Optical Gigabit Ethernet Ports (1000BaseX) with IP65/IP67 Rated fiber optical connectors (type LC)
- 8 - Fast Ethernet Ports (10/100BaseTX) with IP65/IP67 Rated M12 D-code connectors or IP65/IP67 Rated shrouded RJ45 style connectors
- Full compliance with IEEE: 802.3, 802.3u and 802.3z
- Non-blocking, store and forward switching
- Full duplex operation and flow control (IEEE 802.3x)

## RuggedRated™ for Reliability in Harsh Environments

- IP67 Rated for protection against immersion in water
- IP66 Rated for protection against high pressure jets of water
- Meets IEEE 1613 (electric utility substations)
- Exceeds IEC 61850-3 (electric utility substations)
- Exceeds IEEE 61800-3 (variable speed drive systems)
- Exceeds IEC 61000-6-2 (generic industrial environment)
- Exceeds NEMA TS-2 (traffic control equipment)
- -40 to +85°C operating temperature (no fans)
- Conformal coated circuit boards (optional)

## Universal Power Supply Options

- Fully integrated power supply
- Universal high-voltage range: 88-300VDC or 85-264VAC
- Popular low-voltage DC ranges: 12, 24, 48 VDC
- Dual redundant, parallel load-sharing power supplies (option)
- Can be powered from different sources for ultimate redundancy
- Available with M12 or M23 style connectors
- CSA/UL 60950 safety approved to +85°C

## Simple Plug and Play Operation

- Automatic learning of up to 8192 MAC addresses
- Auto-negotiation on all 10/100BaseTX ports
- Auto-MDI/MDIX (crossover) on all 10/100BaseTX ports
- LED indicators for link and activity

## ROS™ Advanced Network Management

- Enhanced Rapid Spanning Tree (eRSTP™)
- Quality of Service (802.1p) for real-time traffic
- Port rate limiting: 128kbps to 8Mbps
- VLAN (802.1q) with double tagging
- IGMP Snooping for multicast filtering
- Port configuration, status, statistics, mirroring, security
- Loss of link management on fiber ports
- Web-based, Telnet, CLI management interfaces
- SNMP v2 and RMON
- Rich set of diagnostics with logging and alarms

## 1.1 RS969 Family Ports/Connectors Description

### RS969 (Mini-Change Connectors)

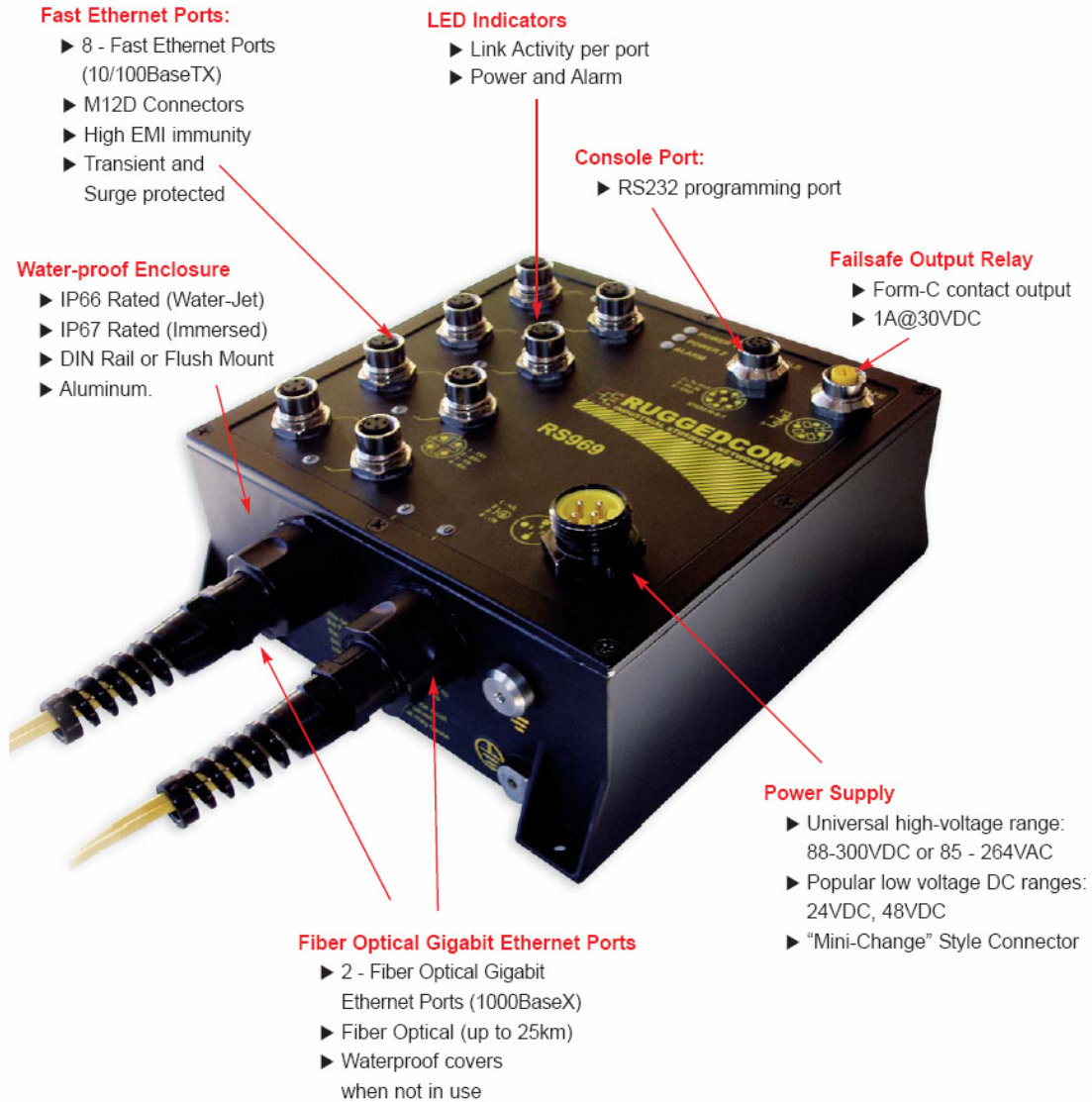

Figure 1.1.1 RS969–M12 with Mini-Change Power Connector

## RS969 (RJ45 Connectors)



Figure 1.1.2 RS969–RJ45 with M23 Power Connector

ITEM	Activity	Comments
LINK LED (Yellow)	Solid	Link Established
	Blinking	Tx/Rx Activity
Power 1 LED	Solid	Power Supply 1 On
Power 2 LED	Solid	Power Supply 2 On
Alarm LED (Red)	Solid	Alarm condition exists



## 2 Installation

### 2.1 DIN Rail Mounting

An optional DIN rail mounting bracket is available for the RS969. Figure 2.1.1 details mounting instructions for the standard 1" DIN Rail.

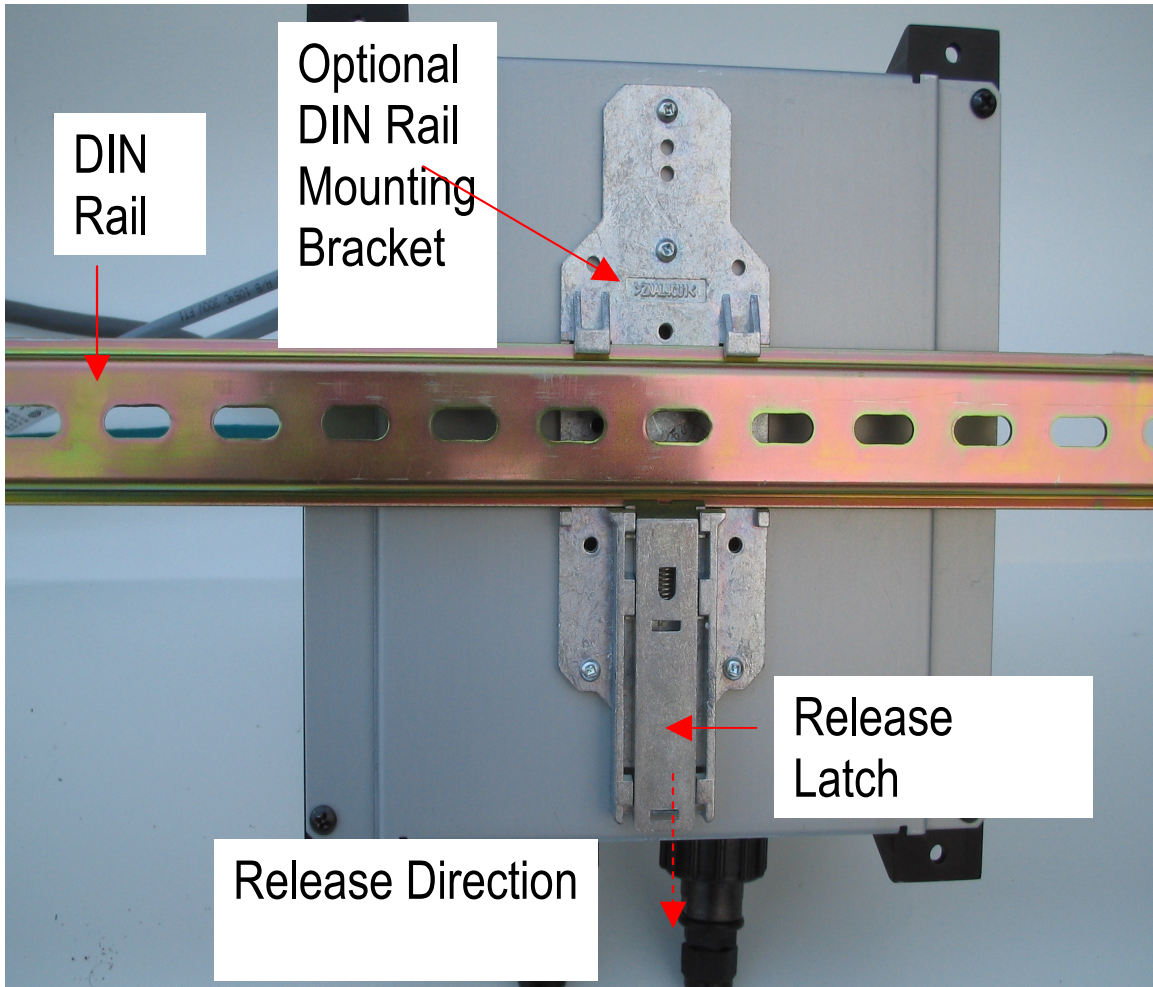

Figure 2.1.1 RS969 Family DIN Rail Mounting

## 2.2 Ingress Protection IP67

IEC International Standard 60529 (Edition 2.1: 2001-02) is a "classification of degrees of protection provided by enclosures as a system for specifying the enclosures of electrical equipment on the basis of the degree of protection provided by the enclosure." These ratings are determined by specific tests

The IP number is composed of two numbers, the first referring to the protection against solid objects and the second against liquids. The higher the IP number, the better the protection. The chart below defines levels of IP ratings.

1st IP#	Degree of protection against access to hazardous parts & ingress of solid objects	2nd IP#	Degree of protection against the ingress of water
0	No protection	0	No protection
1	Protected against solid foreign objects of 50 mm Ø and >	1	Protected against vertically falling water drops
2	Protected against solid foreign objects of 12.5 mm Ø and >	2	Protected against vertically falling water drops when enclosure titled up 15°
3	Protected against solid foreign objects of 2.5 mm Ø and >	3	Protected against spraying water
4	Protected against solid foreign objects of 1.0 mm Ø and >	4	Protected against splashing water
5	Dust protected	5	Protected against jet-water
6	Dust tight	6	Protected against strong jet-water
		7	Protected against the effects of temporary submersion in water
		8	Protected against the effects of permanent submersion in water

The RuggedCom M969 Industrial Ethernet Switch is manufactured and tested to IP67 standards. With an IP67 rating a product will be "dust tight" and remain completely sealed when immersed in water to a depth of 1 meter for 1 hour. (IEC 60529)

These caps completely seals off unused ports on the IP67 Industrial Ethernet Switch. It has an IP67 rated seal that keeps out all contaminants like dirt, oil, and water.





## 2.3 Power Supply Wiring and Grounding

### 2.3.1 Power Supply Input Connectors Description

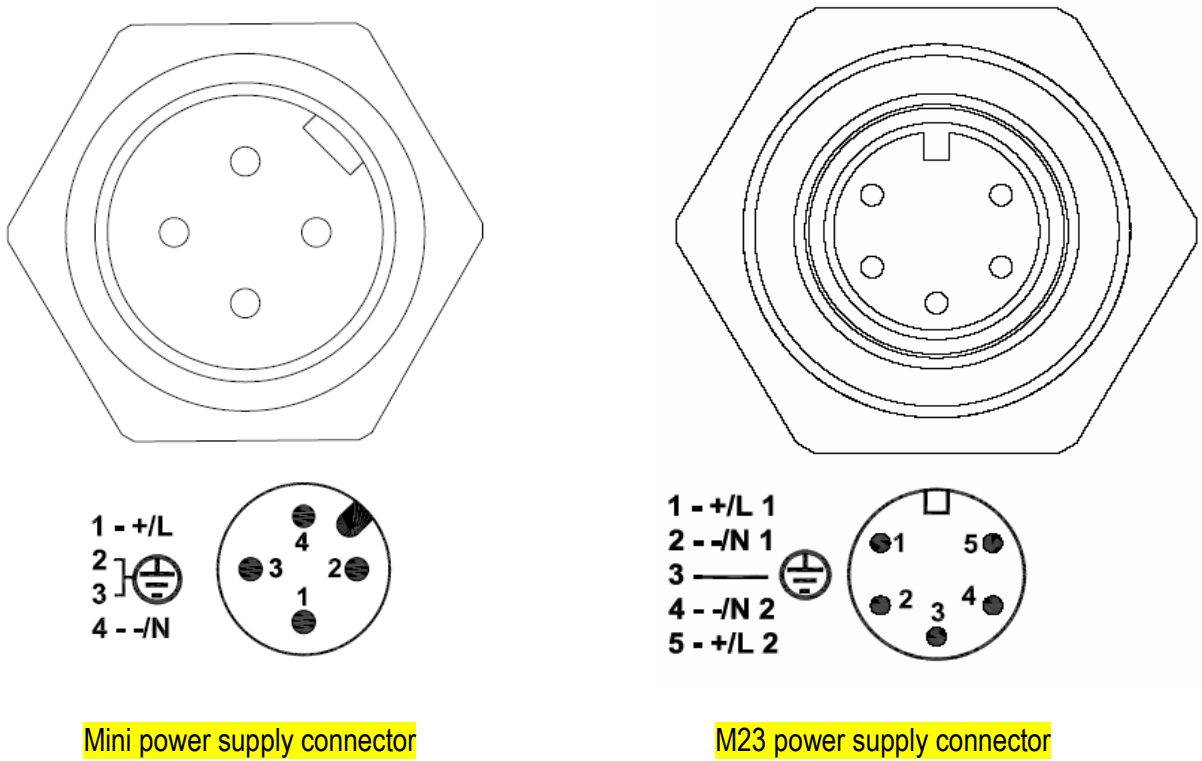

Figure 2.2.1.1 RS969 Family Power Supply Inputs

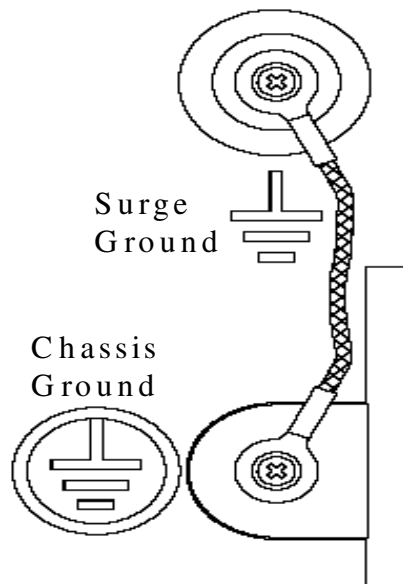

Figure 2.2.1.2 RS969 Family Surge Ground / Chassis Ground Connection

The RS969 family has 2 different power supply input connectors---Mini A-coded male connector or M23 A-code male connector shown in Figure 2.2.1.1. The Mini power connector only has 4 terminals, so only one power supply source is allowed to connect to the RS969 with Mini power connector; The M23 power connector has 5 terminal pins which means 2 power supply sources are allowed to power the RS969 with M23 power connector.

The RS969 family supports dual redundant power supplies – “Power Supply 1 (PS1)” and “Power Supply 2 (PS2)”. The connections for PS1, PS2 are shown in Table1 and 2.

Refer to

Table 1 and 2 for a description of each terminal and sections 2.3.2 through 2.3.4 for wiring examples.

<b>Terminal #</b>	<b>Description</b>	<b>Usage</b>
1	PS1 Live / +	<b>PS1 Live / +</b> is connected to the positive (+) terminal if the power source is DC or to the (Live) terminal if the power source is AC.
2	PS1 Neutral / -	<b>PS1 Neutral / -</b> is connected to the negative (-) terminal if the power source is DC or to the (Neutral) terminal if the power source is AC.
3	Chassis Ground	<b>Chassis Ground</b> is connected to the Safety Ground terminal for AC inputs or the equipment <i>ground bus</i> for DC inputs. This terminal 3 is connected to chassis ground internally in the RS969 family. There is also an additional chassis ground screw and the chassis ground connects to both power supply surge grounds via a removable jumper shown in Figure 2.2.1.2 .
4	PS2 Live / +	<b>PS2 Live / +</b> is connected to the positive (+) terminal if the power source is DC or to the (Live) terminal if the power source is AC.
5	PS2 Neutral / -	<b>PS2 Neutral / -</b> is connected to the negative (-) terminal if the power source is DC or to the (Neutral) terminal if the power source is AC.

Table 1: RS969 Power terminal block connection description for M23 A-code male connector

<b>Terminal #</b>	<b>Description</b>	<b>Usage</b>
1	PS1 Live / +	<b>PS1 Live / +</b> is connected to the positive (+) terminal if the power source is DC or to the (Live) terminal if the power source is AC.
2 3	Chassis Ground	<b>Chassis Ground</b> is connected to the Safety Ground terminal for AC inputs or the equipment <i>ground bus</i> for DC inputs. This terminal 3 is connected to chassis ground internally in the RS969 family. There is also an additional chassis ground screw and the chassis ground connects to both power supply surge grounds via a removable jumper shown in Figure 2.2.1.2 .
4	PS1 Neutral / -	<b>PS1 Neutral / -</b> is connected to the negative (-) terminal if the power source is DC or to the (Neutral) terminal if the power source is AC.

Table 2: RS969 Power terminal block connection description for Mini A-coded male connector

**NOTES:**

1. Equipment must be installed according to the applicable country wiring codes.
2. Surge Ground must be disconnected from the Chassis Ground during HIPOT (dielectric strength) testing.
3. All line-to-ground transient energy is shunted to the Surge Ground terminal. In cases where users require the inputs to be isolated from ground, remove the ground braid between Surge and Chassis Ground. All line-to-ground transient protection circuitry will be disabled.

### 2.3.2 Single AC Power Supply Wiring Examples

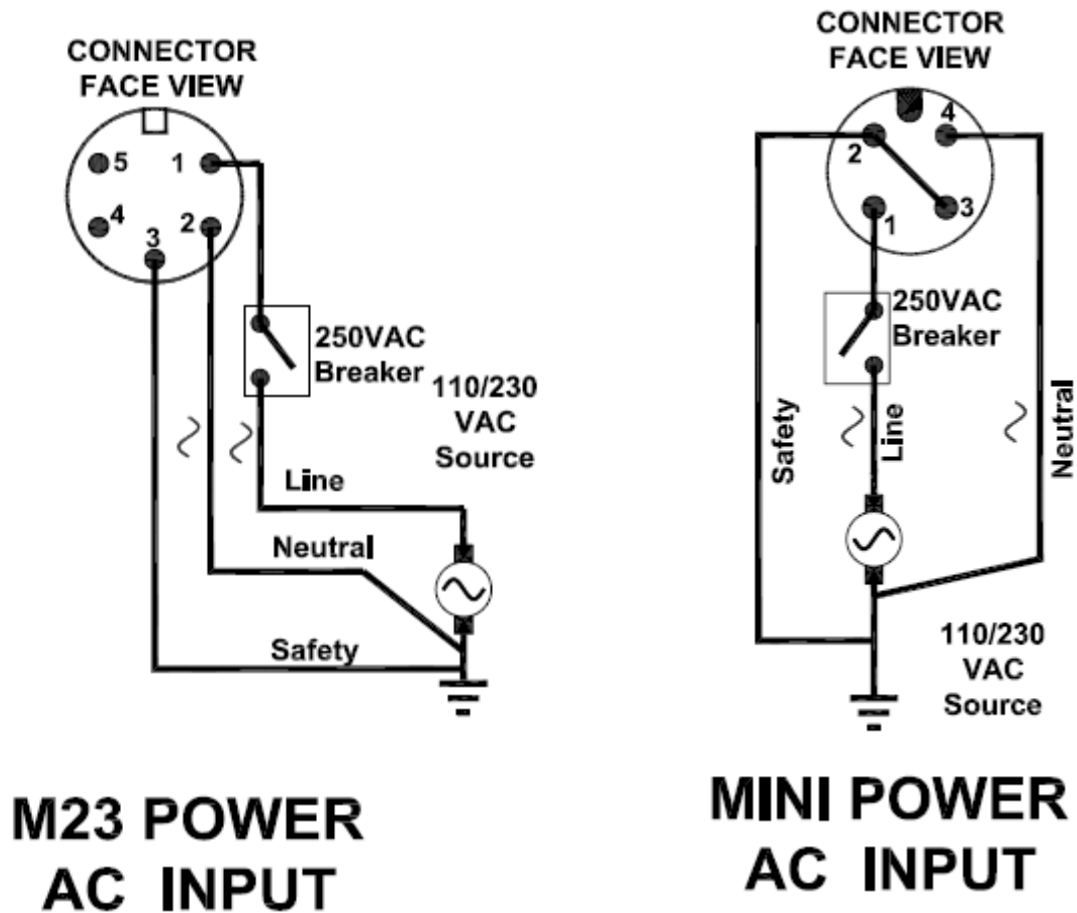

Figure 1: AC Power supply wiring examples

#### NOTES:

1. 100-240VAC rated equipment: A 250VAC appropriately rated circuit breaker must be installed within 3m of unit.
2. Equipment must be installed according to the applicable country wiring codes.
3. When equipped with two HI voltage power supplies, independent AC sources can be used to power the product for greater redundancy.

### 2.3.3 Single DC Power Supply Wiring Examples

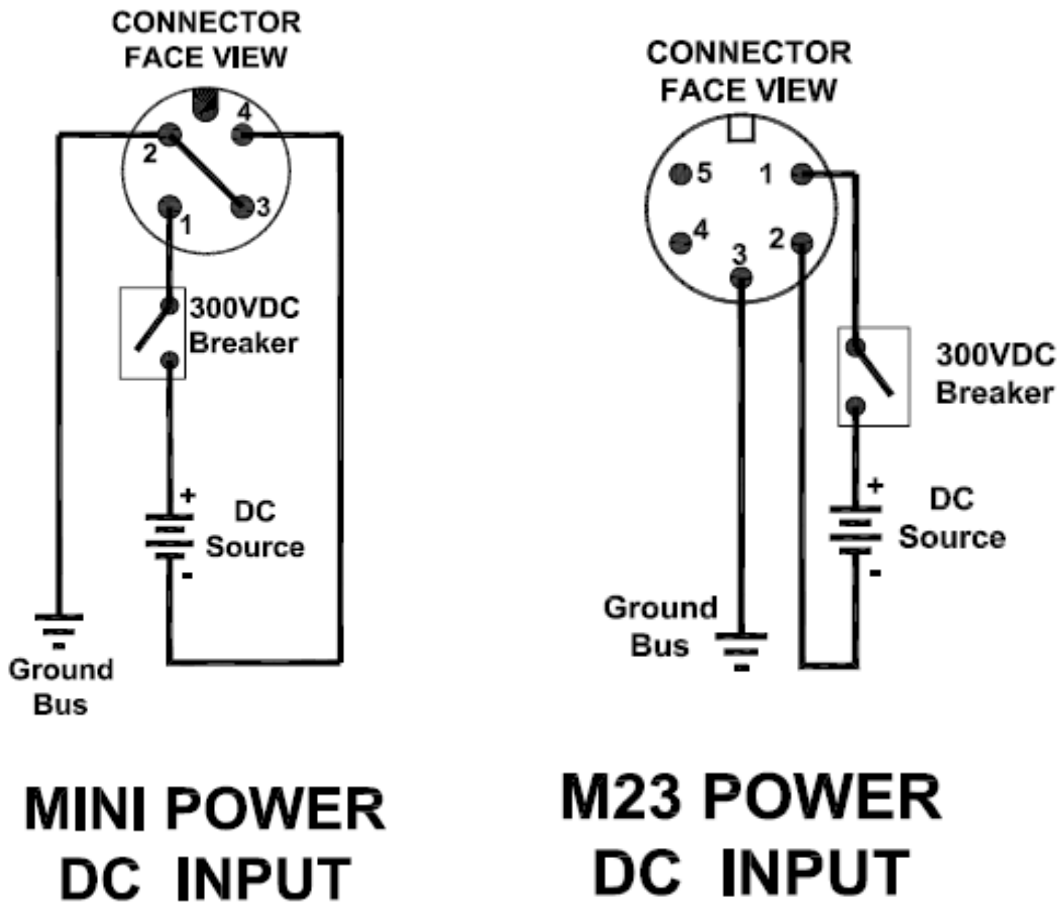
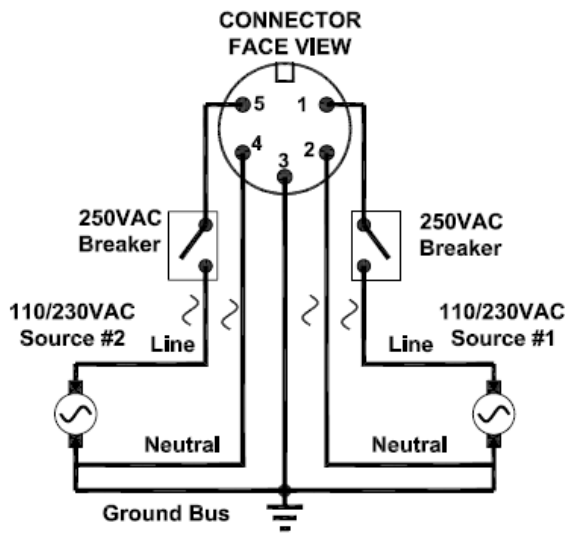

Figure 2: DC Power supply wiring examples

#### NOTES:

1. 88-300VDC rated equipment: A 300VDC appropriately rated circuit breaker must be installed within 3m of unit.
2. A circuit breaker is not required for 12, 24 or 48 VDC rated power supplies.
3. For dual DC power supplies, Separate circuit breakers must be installed and separately identified.
4. Equipment must be installed according to the applicable country wiring codes.

### 2.3.4 Dual Power Supplies – DC and AC Inputs



**M23 POWER  
AC & AC INPUTS**

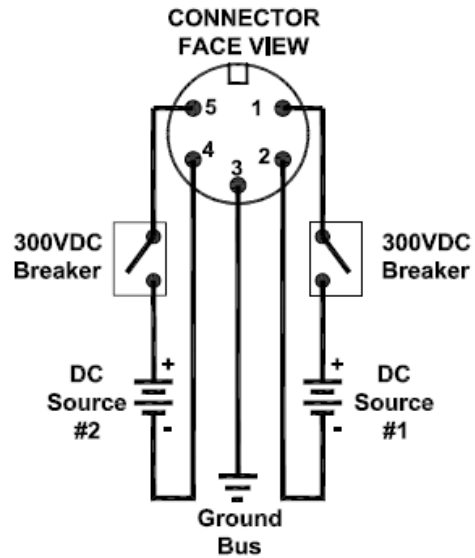

**M23 POWER  
DC & DC INPUTS**

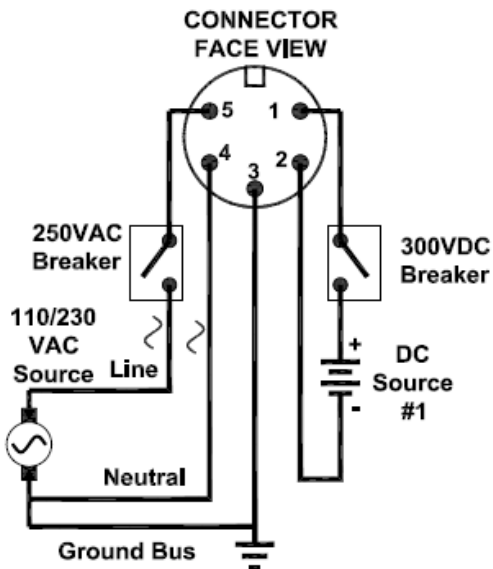

**M23 POWER  
DC & AC INPUTS**



**Figure 3: DC And AC power supply wiring examples**

**NOTES:**

1. 88-300VDC rated equipment: A 300VDC appropriately rated circuit breaker must be installed within 3m of unit.
2. A circuit breaker is not required for 12, 24 or 48 VDC rated power supplies.
3. Separate circuit breakers must be installed and separately identified.
4. Equipment must be installed according to the applicable country wiring codes.

## 2.4 Dielectric Strength Testing

For dielectric strength testing in the field, users must remove the metal jumper located on terminal 2, 4, and 6 of the power supply terminal block. This metal jumper connects transient suppression circuitry to chassis ground, and must be removed in order to avoid damage to protection circuits. Figure 4 shows the proper dielectric strength test connections and should be followed to avoid damage to the device.

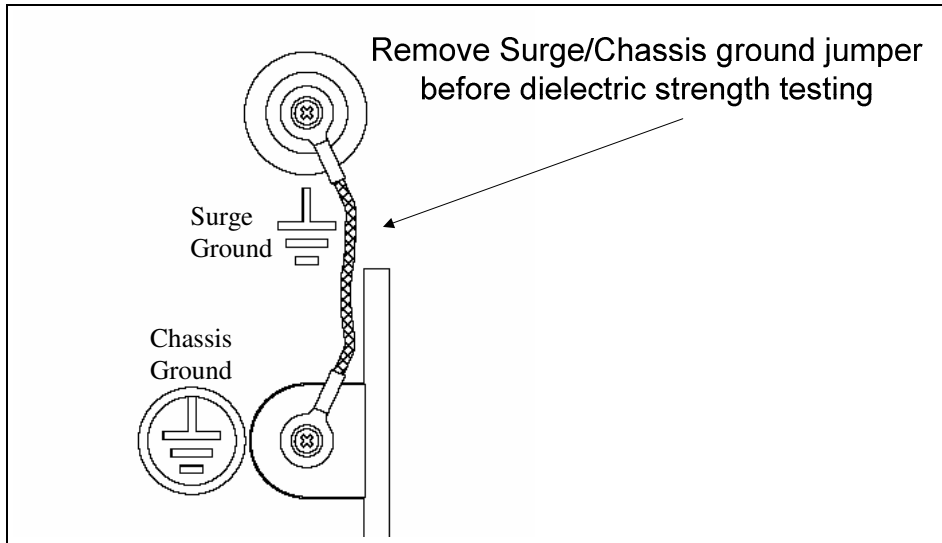

Figure 4: Dielectric Strength (HIPOT) Testing

## 2.5 Failsafe Alarm Relay Wiring and Specifications

The "Failsafe" output relay is provided to signal critical error conditions that may occur on the M969 series switches. The contacts are energized upon power up of the unit and remain energized until a critical error occurs. The proper relay connections are shown in Figure 5 below. One common application for this output is to signal an alarm if a power failure or removal of control power occurs.

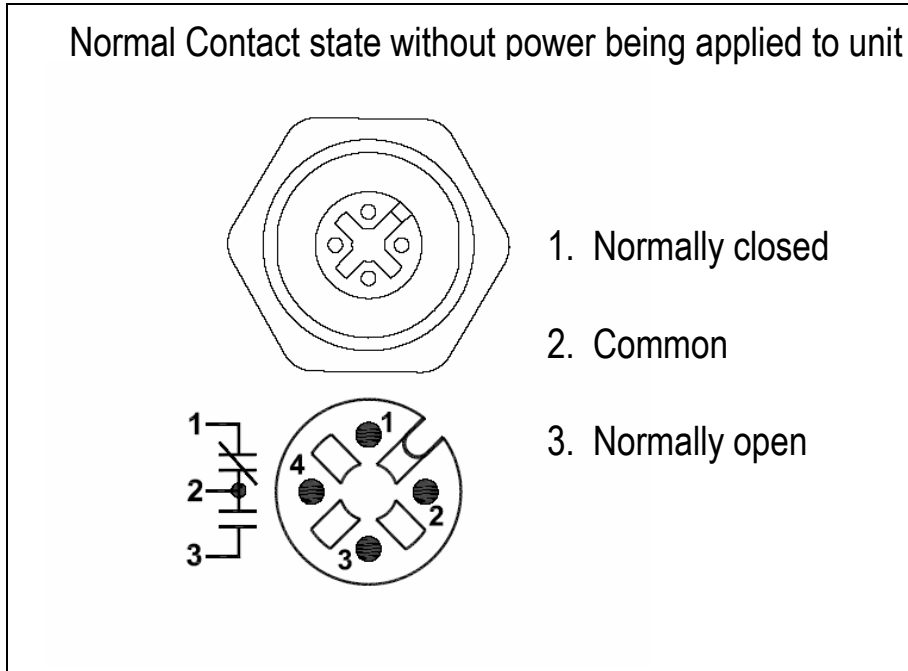

Figure 5: Failsafe Alarm Relay Wiring

## 2.6 Console Port Wiring

A RS232 console port for configuration and management of the device is shown in Figure 6. This port is intended to be a temporary connection during initial configuration or troubleshooting and allows for direct access to the serial-based management console. The connection is made using the DB9-Female to 8-Position-Male-M12 console cable shown in Figure 7. Console connection settings are: 57600 baud, no parity bits, 8 data bits, and 1 stop bit.

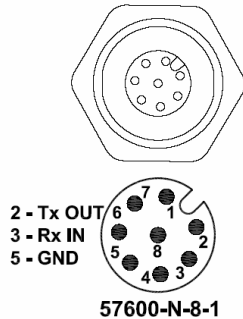

Figure 6: Console port



Figure 7: RS969 Console cable

For user reference, the console cable pin-out is show in Table 5.

<b><i>RuggedCom RS232 over M12 pin-out specification</i></b>		
<i>Signal Name (PC is DTE)</i>	<i>DB9- Female</i>	<i>M12- Male</i>
RxD – Receive data (to DTE)	2	2
TxD – Transmit data (from DTE)	3	3
Signal GND	5	5

Table 2: RS232 over M12 console cable pin-out

After initial configuration, the RuggedSwitch device can be configured via a number of new mechanisms such as Telnet, and the built-in web server. Consult the RuggedSwitch ROS User Guide for further details.

**NOTE:** This port is not intended to be a permanent connection and the cable shall be less than 2m (6.5 ft) in length.

## 2.7 Fast Ethernet Ports – Signal Description

The RS969 series switches have several 10/100BaseTX ports that allow connection to standard CAT-5 UTP cable with industrial RJ45 male connectors or industrial D-coded M12 male connectors. The RJ45/M12 receptacles are directly connected to the chassis ground on the M969 and can accept shielded CAT-5 cables. If shielded cables are used, care must be taken to ensure the shielded cables do not form a ground loop via the shield wire and the RJ45/M12 receptacles at either end. Figure 2.6.1 shows the pin configuration.

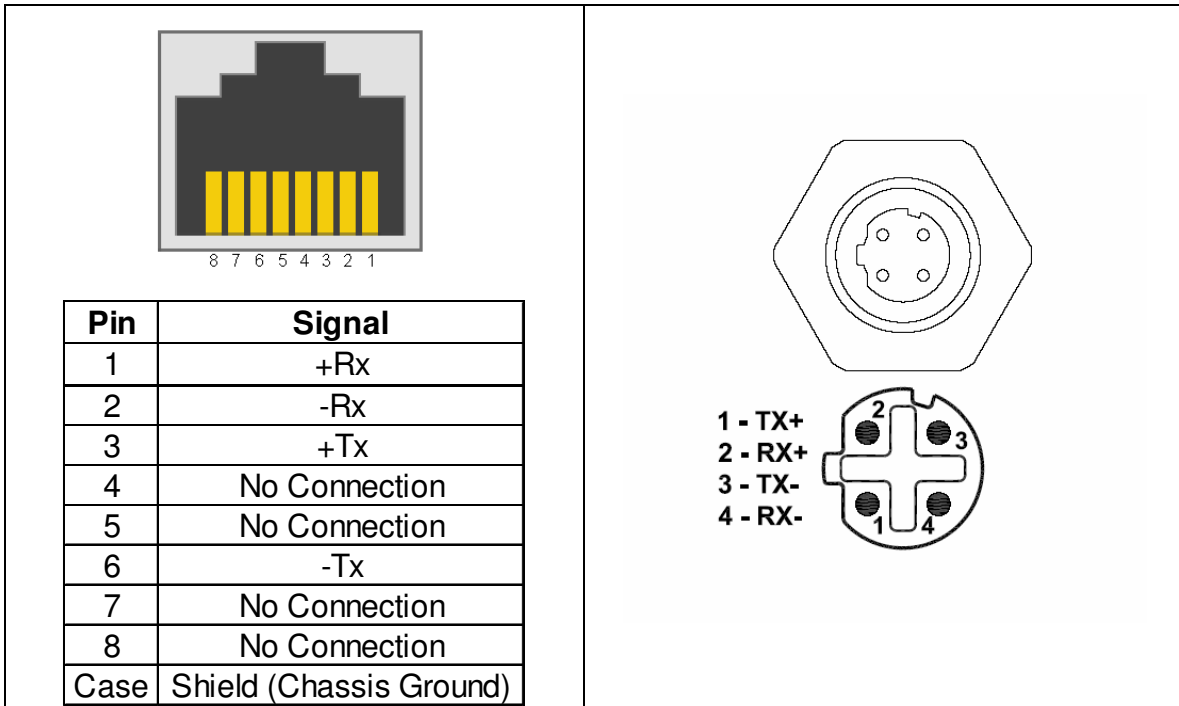

Figure 2.6.1 RJ45 Port and M12 Port Pins

**NOTE:** RuggedCom does not recommend the use of CAT-5 cabling of any length for critical real-time substation automation applications. However, transient suppression circuitry is present on all copper ports to protect against damage from electrical transients and to ensure IEC 61850-3 and IEEE 1613 Class 1 conformance. This means that during the transient event communications errors or interruptions may occur but recovery is automatic.

RuggedCom also does not recommended to use these ports to interface to field devices across distances which could produce high levels of ground potential rise, (i.e. greater than 2500V) during line to ground fault conditions.

## 3 Technical Specifications

### 3.1 Operating Environment

Parameter	Range	Comments
Ambient Operating Temperature	-40 to 85°C	Ambient Temperature as measured from a 30 cm radius surrounding the center of the M969 enclosure.
Ambient Relative Humidity	5% to 95%	Non-condensing
Ambient Storage Temperature	-40 to 85°C	
IP Rating	IP67	
Operating Altitude	0 to 15240m (0 to 50000 ft)	Over temperature range of -40 to 85°C

### 3.2 Power Supply Specifications

Power Supply Type	Minimum Input	Maximum Input	Fuse Rating	Isolation	Maximum Power Consumption
12 – 24 VDC	10 VDC	36 VDC	3.15A (T)	1.5 kV DC	10W
24 VDC	18 VDC	36 VDC	3.15A (T)	1.5 kV DC	
48 VDC	36 VDC	72VDC	3.15A (T)	1.5 kV DC	
HI (125/250 VDC) <sup>1</sup> HI (110/230 VAC) <sup>1</sup>	88 VDC 85 VAC	300 VDC 265 VAC	3.15A (T)	4 kV AC 5.5 kV DC	

**NOTES:**

1. This is the same power supply for both AC and DC.
2. (T) denotes time-delay fuse
3. For continued protection against risk of fire, replace only with same type and rating of fuse.

### 3.3 Failsafe Relay Specifications

Parameter	Value
Max Switching Voltage	30VAC, 80VDC
Rated Switching Current	0.3A @ 30VAC 1A @ 30VDC, 0.3A @ 80VDC

**NOTES:**

1. Resistive Load.
2. For Class-2 circuits only.



<i>Isolation</i>	<i>Comments</i>
1500 V <sub>rms</sub>	Dielectric test voltage (1 minute) between coil & contacts

### **3.4 Twisted Pair Data Port Specifications**

<i>Data Port</i>	<i>Media</i>	<i>Distance</i>	<i>Connector Type</i>
10/100 Mbps	Cat 5 UTP or STP	100m	RJ45 or M12

### **3.5 Fiber Optical Port Specifications**

For maximum flexibility RuggedCom Inc. offers a number of different transceiver choices for Gigabit fiber optical communications. The following table details fiber optic specifications based on the order code / transceiver selected at time of ordering.

<b>Order Code</b>	<b>Mode / Connector</b>	<b>Tx <math>\lambda</math> (nm)</b>	<b>Cable Type<sup>2</sup></b>	<b>Tx Pwr (dBm)<sup>3</sup> (Min/Max)</b>	<b>Rx Sensitivity (dBm)<sup>3</sup></b>	<b>Rx Saturation (dBm)<sup>3</sup></b>	<b>Typical Distance<sup>1</sup> (km)</b>	<b>Power Budget (dB)</b>
2LCMM	MM / LC	850	50 $\mu$ /125	-9.5 / -4	-20	0	0.5	13
2LC10	SM / LC	1310	9 $\mu$ /125	-9.5 / -3	-22	-3	10	18.5
2LC25	SM / LC	1310	9 $\mu$ /125	-5 / 0	-22	-3	25	19.5

**NOTES:**

1. Maximum segment length is greatly dependent on factors such as fiber quality, and number of patches and splices. Please consult RuggedCom sales associates when determining maximum segment distances.
2. All cabling is duplex type unless otherwise specified.
3. All optical power numbers are listed as dBm averages.

### 3.6 IEC 61850-3 Type Tests

Test	Description		Test Levels	Severity Levels
IEC 61000-4-2	ESD	Enclosure Contact	+/- 8kV	4
		Enclosure Air	+/- 15kV	4
IEC 61000-4-3	Radiated RFI	Enclosure ports	20 V/m	x
IEC 61000-4-4	Burst (Fast Transient)	Signal ports	+/- 4kV @ 2.5kHz	x
		D.C. Power ports	+/- 4kV	4
		A.C. Power ports	+/- 4kV	4
		Earth ground ports	+/- 4kV	4
IEC 61000-4-5	Surge	Signal ports	+/- 4kV line-to-earth, +/- 2kV line-to-line	4
		D.C. Power ports	+/- 2kV line-to-earth, +/- 1kV line-to-line	3
		A.C. Power ports	+/- 4kV line-to-earth, +/- 2kV line-to-line	4
IEC 61000-4-6	Induced (Conducted) RFI	Signal ports	10V	3
		D.C Power ports	10V	3
		A.C. Power ports	10V	3
		Earth ground ports	10V	3
IEC 61000-4-8	Magnetic Field	Enclosure ports	40 A/m continuous, 1000 A/m for 1 s	N/A
IEC 61000-4-29	Voltage Dips & Interrupts	D.C. Power ports	30% for 0.1s, 60% for 0.1s, 100% for 0.05s	N/A
IEC 61000-4-11		A.C. Power ports	30% for 1 period, 60% for 50 periods 100% for 5 periods, 100% for 50 periods <sup>2</sup>	N/A
IEC 61000-4-12	Damped Oscillatory	Signal ports	2.5kV common, 1kV differential mode @ 1MHz	3
		D.C. Power ports	2.5kV common, 1kV differential mode @ 1MHz	3
		A.C. Power ports	2.5kV common, 1kV differential mode @ 1MHz	3
IEC 61000-4-16	Mains Frequency Voltage	Signal ports	30V Continuous, 300V for 1s	4
		D.C. Power ports	30V Continuous, 300V for 1s	4
IEC 61000-4-17	Ripple on D.C. Power Supply	D.C. Power ports	10%	3
IEC 60255-5	Dielectric Strength	Signal ports	2kV AC (Fail-Safe Relay output)	N/A
		D.C. Power ports	2kV AC	N/A
		A.C. Power ports	2kV AC	N/A
IEC 60255-5	H.V. Impulse	Signal ports	5kV (Fail-Safe Relay output)	N/A
		D.C. Power ports	5kV	N/A
		A.C. Power ports	5kV	N/A

### 3.7 IEEE 1613 Type Tests

IEEE Test	IEEE 1613 Clause	Description		Test Levels
C37.90.3	9	ESD	Enclosure Contact	+/- 8kV
			Enclosure Air	+/- 15kV
C37.90.2	8	Radiated RFI	Enclosure ports	35 V/m
C37.90.1	7	Fast Transient	Signal ports	+/- 4kV @ 2.5kHz
			D.C. Power ports	+/- 4kV
			A.C. Power ports	+/- 4kV
			Earth ground ports	+/- 4kV
C37.90.1	7	Oscillatory	Signal ports	2.5kV common mode @ 1MHz
			D.C. Power ports	2.5kV common & differential mode @ 1MHz
			A.C. Power ports	2.5kV common & differential mode @ 1MHz
C37.90	6	H.V. Impulse	Signal ports	5 kV (Failsafe Relay)
			D.C. Power ports	5 kV
			A.C. Power ports	5 kV
C37.90	6	Dielectric Strength	Signal ports	2kV AC(Failsafe Relay)
			D.C. Power ports	2kV AC
			A.C. Power ports	2kV AC

**NOTES:**

- If the unit contains copper ports the IEEE 1613 conformance is Class 1 (During disturbance errors may occur but recovery is automatic).
- If the unit contains all fiber ports the IEEE 1613 conformance is Class 2 (During disturbance no errors will occur).

### 3.8 IEC Environmental Type Tests

Test	Description		Test Levels	Severity Levels
IEC 60068-2-1	Cold Temperature	Test Ad	-40 deg. C, 16 Hours	N/A
IEC 60068-2-2	Dry Heat	Test Bd	+85 deg. C, 16 Hours	N/A
IEC 60068-2-30	Humidity (Damp Heat, Cyclic)	Test Db	95% (non-condensing), 55°C, 6 cycles	N/A
IEC 60255-21-1	Vibration	Tests Fc	2g @ (10-150) Hz	Class 2
IEC 60255-21-2	Shock	Tests Ea	30g @ 11 ms	Class 2
IEC 60529 (IPx6)	Ingress Protection	Water Jet	100l/m @ 2.5m as per 14.2.6	N/A
IEC 60529 (IPx7)	Ingress Protection	Water Submersion	30 min @ 1m as per 14.2.7	N/A
IEC 60529 (IP6x)	Ingress Protection	Dust Talcum	2kg/m3 for 8h as per 13.4	Cat. 1&2





### **3.10 Agency Approvals**

<b>Agency</b>	<b>Standards</b>	<b>Comments</b>
CSA	CSA C22.2 No. 60950, UL 60950	Approved
CE	EN 60950, EN 61000-6-2	Approved
FCC	FCC Part 15, Class A	Approved
CISPR	EN55022, Class A	Approved
FDA/CDRH	21 CFR Chapter 1, Subchapter J	Approved
IEC/EN	EN60825-1:1994 + A11:1996 + A2:2001	Approved



## 4 Accessories

### 4.1 POWER (1/unit)

#### M23 Power Mating Connector

Description: M23 5pin female connector, 600V, IP68 rated, RuggedCom P/N 30-50-0012

Cable specs: 3/18AWG, jacket OD range 0.20" - 0.48"

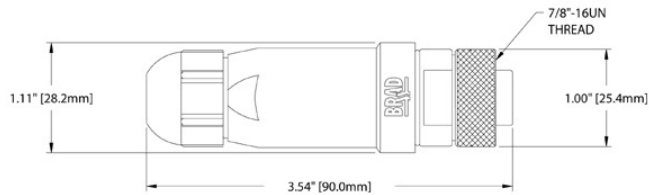

#### MINI Power Mating Cordset

Description: MINI-Change 4pin female connector; 4/16AWG, rubber jacket cable, 600V, 3 meters

RuggedCom P/N 43-10-0031

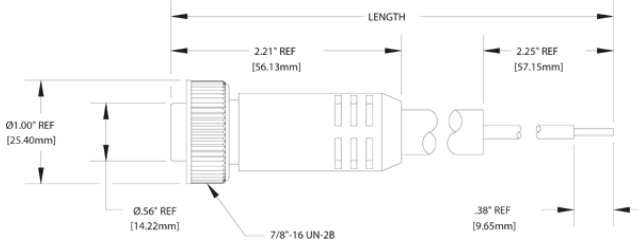

### 4.2 CONSOLE (1/unit)

#### M12 Console Port Mating Cable

Description: M12 8pin A-code male to DB9 female; unshielded, PUR jacket cable, 30V/4A, 3m

RuggedCom P/N 43-10-0023

Cable specs: M12 8pin A-code male to free end, 3m

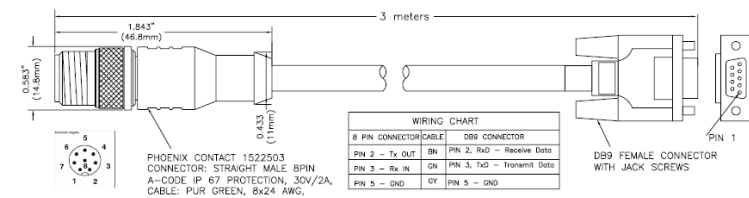

### **M12 Console Port Mating Connector**

Description: M12-straight plug, 8 pole, A-coded, IP67 rated  
RuggedCom P/N 30-50-0018

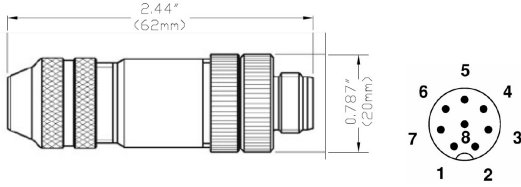

### **4.3 FAILSAFE (1/unit)**

#### **M12 FailSafe Port Mating Cable**

Description: M12 4pole A-coded; unshielded, PUR Jacket cable, 3m  
RuggedCom P/N 43-10-0024

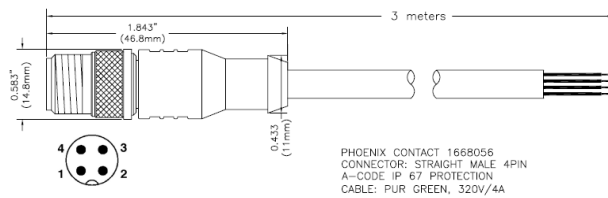

#### **M12 FailSafe Port Mating Connector**

Description: M12-straight plug, 4 pole, A-coded, IP67 rated  
RuggedCom P/N 30-50-0017

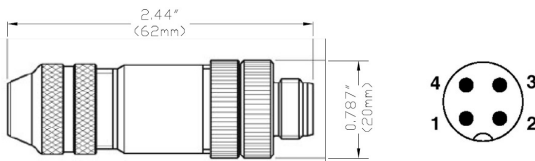

## 4.4 ETHERNET (8/unit)

### M12 D-code Ethernet Port Mating Cable

Description: M12 D-code to RJ45; patch cable, 3meters

RuggedCom P/N 43-10-0033

Cable specs: M12 dcode male 4PIN, CAT5e, 3m

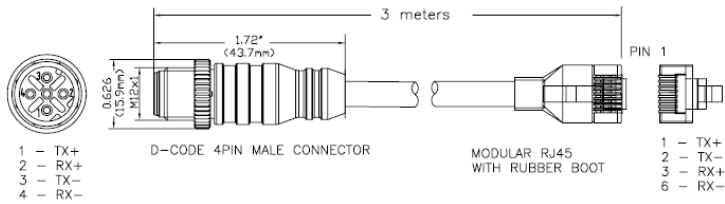

### M12 D-code Ethernet Port Mating Connector

Description: M12-straight plug, 4 pole, D-coded, IP67 rated

RuggedCom P/N 30-50-0015

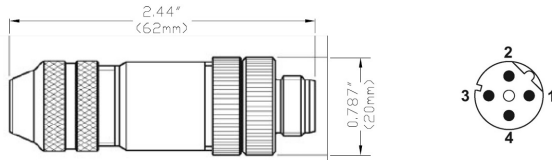

### IP67 RJ45 Ethernet Port Mating Cable

Description: IP67 RJ45 plug to RJ45; Category 5e shielded patch cable, 3.1m

RuggedCom P/N 43-10-0029

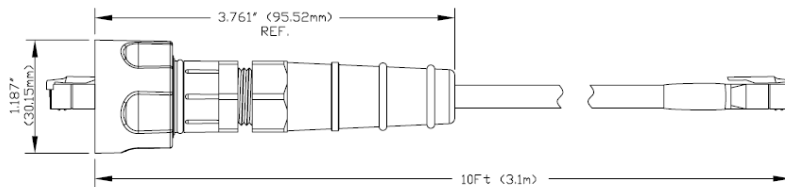

**IP67 RJ45 Ethernet Port Mating connector**

Description: IP67 RJ45 plug, field attachable

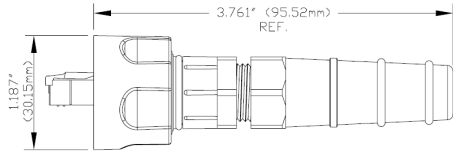

**4.5 LC FIBER OPTIC (2/unit)**

**LC Port Mating Connector**

Description: IP67 Multimode LC plug  
RuggedCom P/N 30-50-0010

Description: IP67 Singlemode LC plug  
RuggedCom P/N 30-50-0023

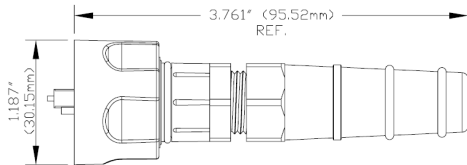

**LC Port Mating Connector**

Description: Multimode IP67 LC plug to LC connector, 3m  
RuggedCom P/N 43-10-0044

Description: Singlemode IP67 LC plug to LC connector, 3m  
RuggedCom P/N 43-10-0043

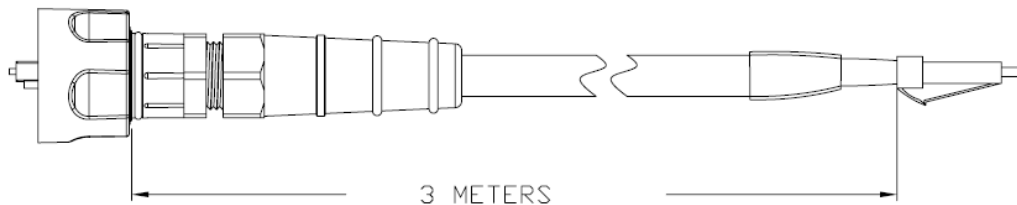

## 5 Warranty

Five (5) years from date of purchase, return to factory. For warranty details, visit [www.ruggedcom.com](http://www.ruggedcom.com) or contact your customer service representative.

Should this product require warranty or service contact the factory at:

RuggedCom Inc.  
30 Whitmore Road,  
Woodbridge, Ontario  
Canada L4L 7Z4

Tel: (905) 856-5288  
Fax: (905) 856-1995  
Toll Free: (888) 264-0006